

### ADROIT Oil Mist Collector (AOMC SERIES)

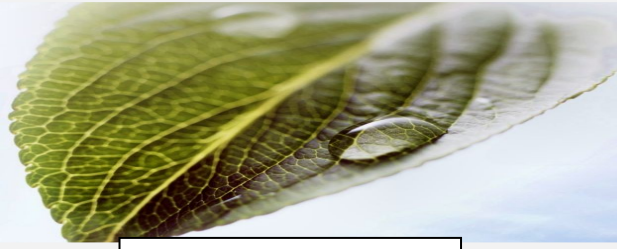

### COMPACT MEDIA FILTER PORTABLE OIL MIST COLLECTOR

#### OUTLINE

The AOMC Series is a Media Filter Type Oil Mist Collector Unit capable of capacity up to 6000CFM.

It would suitable for application like wet machining, grinding, milling, turning, milling, drilling and other manufacturing and process applications that generate wet contaminants.

#### *Machines come complete with:*

- \* Leg Support
- \* Control Panel
- \* Waste Oil Drain Port

#### *Optional Parts:*

- \* Extraction Arm
- \* Activated Carbon Adsorber
- \* HEPA Filter
- \* Differential Pressure Gauge

#### *Cautions:*

- \* Do not extract spark.
- \* Ground for prevention of electric shock



#### Housing

Welded, oil-proof, inside and outside epoxy powder coated. Made from 2mm mild steel sheets. Dirty air inlet from top direction. Access door to fan compartment at rear side of unit with lift and turn compression latch. Clean air outlet on unit back.

Powder coated color code: RAL5021

(or to customer's spec. against extra charge)



## General Technical Information

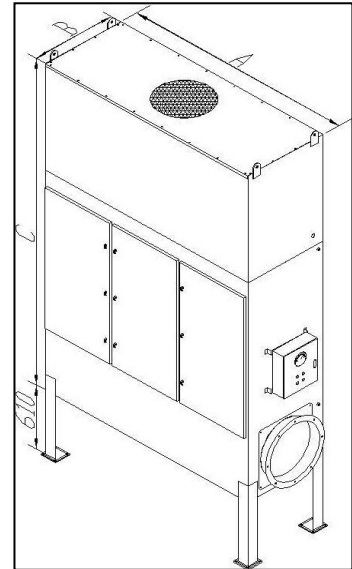
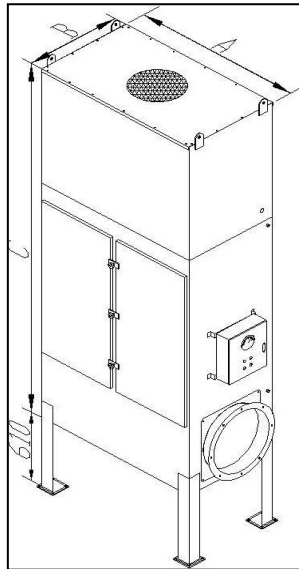
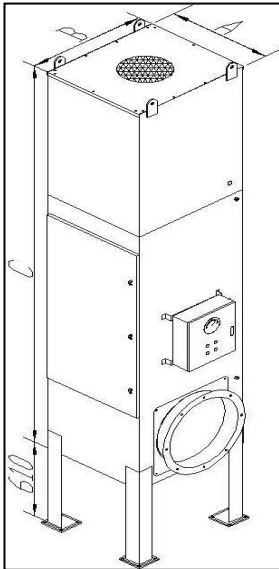

## Specification

Model	Motor (kW)	Airflow (m <sup>3</sup> /min)	Static Pre- sure (mmH <sub>2</sub> O)	Filter				Power Supply	Weight (Kg)
				A	B	C	Inlet		
AOMC-100	1.5	30	150	559	635	1003	Ø200	415V/3ph/50Hz	80
AOMC-200	5.5	60	240	685	610	2125	Ø250		130
AOMC-400	11.5	115	240	1372	780	2445	Ø350		265
AOMC-600	15.5	170	250	2058	780	2575	Ø450		320

### Electrical Ventilator Unit

- \* (IEC standards)
- \* Direct driven blower fan with IP55 EFF2 standard motor,
- \* 415volts/3phase/50Hz
- \* Connection cable 3m length.

### Optional After Filter Elements

Filter Cartridge.

1. HEPA Filter for 99.97% @ 0.3µm filtration efficiency
2. Activated Carbon Filter for odor filtration

### Contact Us:

# ADROIT

**ADROIT TECHNOLOGY SDN BHD** (1031190-D)

2-1B, JALAN BANDAR LAPAN,  
PUSAT BANDAR PUCHONG,  
47100, PUCHONG, SELANGOR.

Tel: +603 – 5891 0278 Fax: +603 – 5891 1178

Sales Care line : +6019 – 4734840 (Mr. Eric Teoh)

Website : [www.adroitmy.com](http://www.adroitmy.com)

Email : [inquiry@adroitmy.com](mailto:inquiry@adroitmy.com)

### Filter Elements

1<sup>st</sup> Stage : Washable Aluminum Impingers Filter

2<sup>nd</sup> Stage : Washable Aluminum Mesh Filter

3<sup>rd</sup> Stage : Multi-Vee Oil Mist Filter Bag

**DESIGN, MANUFACTURE, INSTALL & SERVICE...**